

E250 Cylinders



The RSH cylinders bodies and fittings are made of black hard-coated aluminum and AISI 316 steel for the rod.

The standard range is optimized for work with the last generation of yacht layout.

On request they can be supplied with custom stroke, push-pull version or according to specific needs.

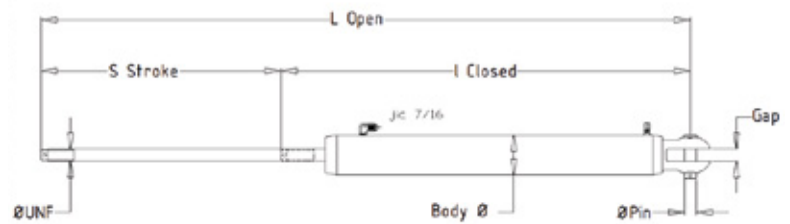

Technical Data

Ref.	Description	Max pull force @ 5000PSI	Body Ø (mm)	Gap / Pin (in)	Thread (UNF)	L Open (mm)	L Closed (mm)	Stroke (mm)	Weight (kg)
E250-LE-010	-10 LE Cylinder	2630	42	1/2	1/2-20	907	564	343	1,38
E250-LE-012	-12 LE Cylinder	3450	52	5/8	5/8-18	960	600	360	2,37
E250-LE-017	-17 LE Cylinder	4940	57	5/8	5/8-18	962	602	360	2,63
E250-LE-022	-22 LE Cylinder	6300	63	3/4	3/4-16	1030	650	380	3,61
E250-LE-030	-30 LE Cylinder	10020	82	7/8	7/8-14	1132	713	419	6,48
E250-LE-040	-40 LE Cylinder	14610	101	1	1-12	1243	786	457	10,45
E250-LE-060	-60 LE Cylinder	19460	114	1 1/4	1 1/4-12	1437	904	533	15,96
E250-LE-090	-90 LE Cylinder	26170	140	1 3/8	1 1/4-12	1346	743	603	25,84

E850 Vang



RSH hydraulic vang guarantees maximum traction power combined with the powerful pushing force as well as the comfort to trim directly from the cockpit. It allows the meticulous control of the leech tension sailing in strong wind as in light airs supporting the weight of the boom. When the sail is flaked it acts as topping lift.

The construction of the **RSH E850 vangs** provides a pressurization with high pressure inert gas making them among the lightest and best performing on the market

On request they can be supplied in a hydraulic Push-Pull configuration.

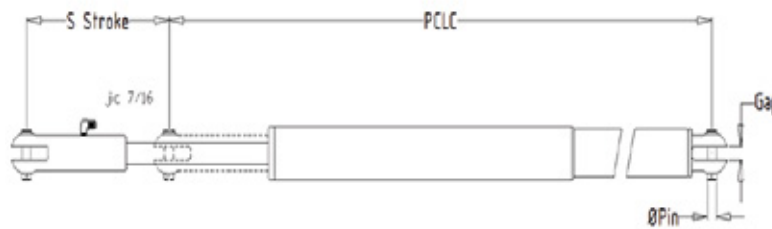

Technical Data

Ref.	Description	Max pull force @ 5000PSI	Return force @ 600 PSI (kg)	Gap / Pin (in)	Stroke (mm)	PCLC (mm)
E850-VC-017	-17 Vang – gas return	3180	680	5/8	241	Custom
E850-VC-022	-22 Vang – gas return	4660	880	5/8	254	Custom
E850-VC-030	-30 Vang – gas return	7210	1370	3/4	280	Custom
E850-VC-040	-40 Vang – gas return	11640	1960	7/8	305	Custom
E850-VC-060	-60 Vang – gas return	15570	2670	1	357	Custom
E850-VC-090	-90 Vang – gas return	19210	3470	1 1/4	406	Custom

Custom Cylinders



In addition to the standard range we can supply actuators designed and built according to special need.

On request we produce cylinders with customized stroke, with special terminals or in push-pull versions.

We can meet the aesthetic needs of the owners of classic boats with our line of stainless steel cylinders and panels.

For projects in which pure performance is sought, special materials can be used for a product with very high performance and minimal weight.

We are ready to welcome any project request and make available our experience to find the best solution together.

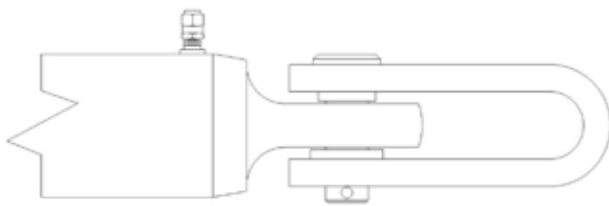

Cilindro con finale ad occhio

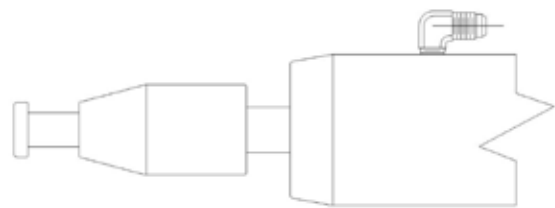

Terminale per bozzello

E254 Double rod cylinders

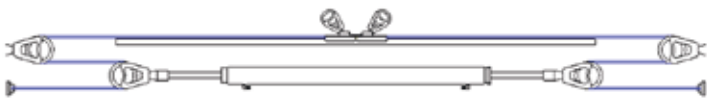

They are double-acting cylinders and are born for the control of the mainsheet travellers but they are also used for the movement of the genoa cars or other custom functions.

Normally they are used with a 2:1 or 3:1 inverse tackle, which is why a range of accessories is available for coupling with many of the blocks on the market.

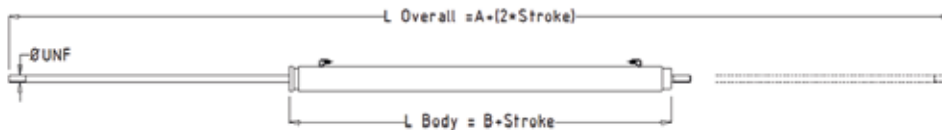

Technical Data

Ref.	Description	Max pull force @ 5000PSI	Body Ø (mm)	Thread (UNF)	A (mm)	B (mm)	Stroke (mm)
E254-XX-010	-10 double rod cylinder	2630	42	1/2-20	312	243	Custom
E254-XX-012	-12 double rod cylinder	3450	52	5/8-18	340	250	Custom
E254-XX-017	-17 double rod cylinder	4940	57	5/8-18	352	265	Custom
E254-XX-022	-22 double rod cylinder	6300	63	3/4-16	396	278	Custom
E254-XX-030	-30 double rod cylinder	10020	82	7/8-14	405	348	Custom
E254-XX-040	-40 double rod cylinder	14610	101	1-12	502	363	Custom

E320 Manual Panel



The **E320 manual panel** is the simplest way to operate your hydraulic system.

Can be configured to control a single function (SF) or up to four functions in the multi-function version (MF).

It can be mounted alone for manual use only or in combination with the CLP series electric pumps.

In the most complete systems it can be used as a manual backup.

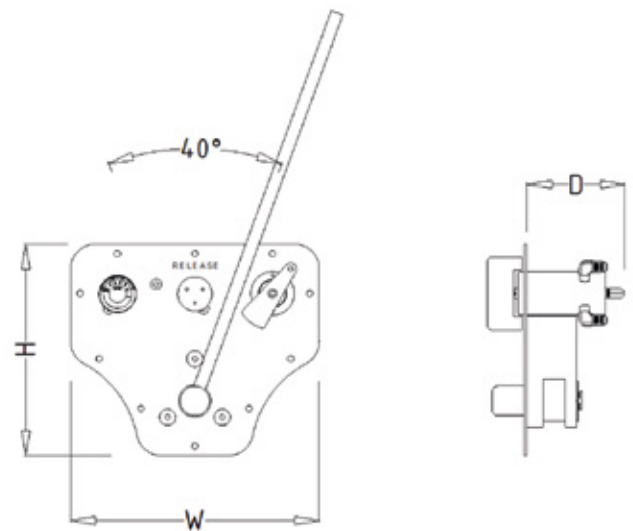

Technical Data

Ref.	Description	L (mm)	W (mm)	H (mm)
E320-SF-01	Single function Panel	216	254	95
E320-MF-01	Up to four Function panel	216	254	115

Solenoid valve blocks



They are assembled using components of the highest quality and can be configured with various types of valves for different needs.

The CLF line is the result of several years of collaboration with "Nuove Tecnologie":

CLF-01 valve: designed to operate all the standard cylinders, it allows the control of the oil flow in supply and in release mode and incorporates the discharge speed adjustment.

It can be equipped with pressure transducer just for a remote display or for interfacing with the PLC for more complex features.

CLF-350 valve: it is the "race" evolution of CLF, optimized for use with higher pressure range, it allows to manage more performing systems with more compact, light and fast actuators.

The range of application is vast and can include all the other onboard hydraulic functions (rotary and winding) and linear (single or double acting cylinders) and whatever the range of pressure and oil flow they need.

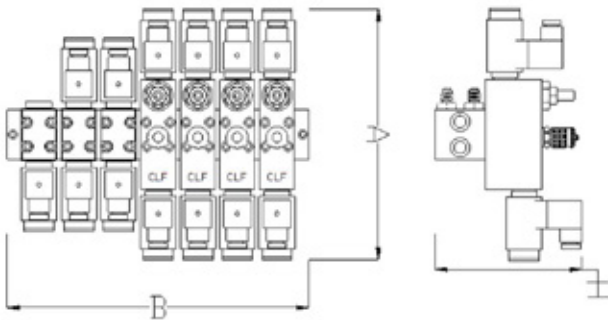

Technical Data

Ref.	Description	A (mm)	B (mm)	H (mm)	Weight (kg)
CLF-02	2 way CLF valve block	252	104	147	2.5
CLF-03	3 way CLF valve block	252	144	147	3.7
CLF-04	4 way CLF valve block	252	184	147	4.9
CLF-05	5 way CLF valve block	252	223	147	6.1
CLF-06	6 way CLF valve block	252	264	147	7.3
CLF-07	7 way CLF valve block	252	303	147	8.5
CLF-08	8 way CLF valve block	252	342	147	9.7

On-board hydraulic systems



That oil is an excellent vehicle for transferring energy from a source to an actuator, in the nautical sector, has been understood since the '70s and already from the following decade its spread on boats made hydraulics an inalienable reality.

Since then we have come a long way and the hydraulics of our day allows us things that were previously unimaginable, especially in terms of size, weight and versatility.

In recent years to meet the needs of the latest generation of yachts we have made a great effort in the search for systems with low energy impact and that ensure maximum silent operation

Our product lines:

With our line of **RSH** cylinders and control units we guarantee the movement of all sailing maneuvers, both in the classic manual configuration and with various more or less sophisticated engine levels.

The **CLP** line with its great flexibility of customization allows us to propose systems for the management of all the hydraulic functions on board both linear (cylinders) and rotary like winches, winders or propellers.

The interface with electronic controllers allows us to program automatism and synergies between functions such as, for example, the movement of the keels and their locking systems.

We can manage different power sources at the same time to have, when needed, the maximum power available as, for example, in the operation of bow-thrusters.

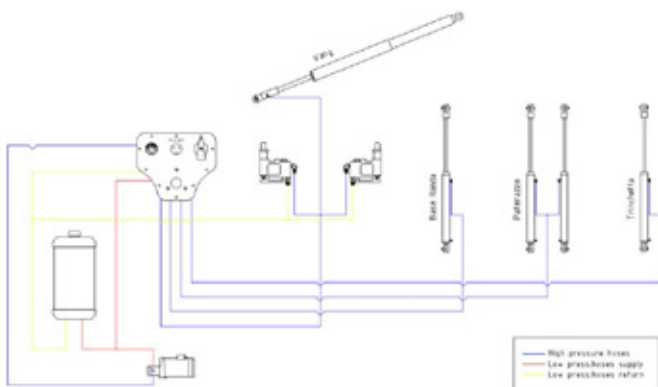
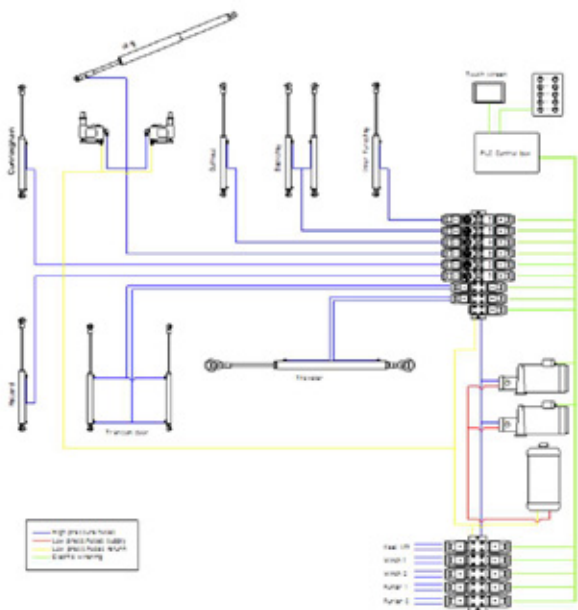

Electric control panels CLE

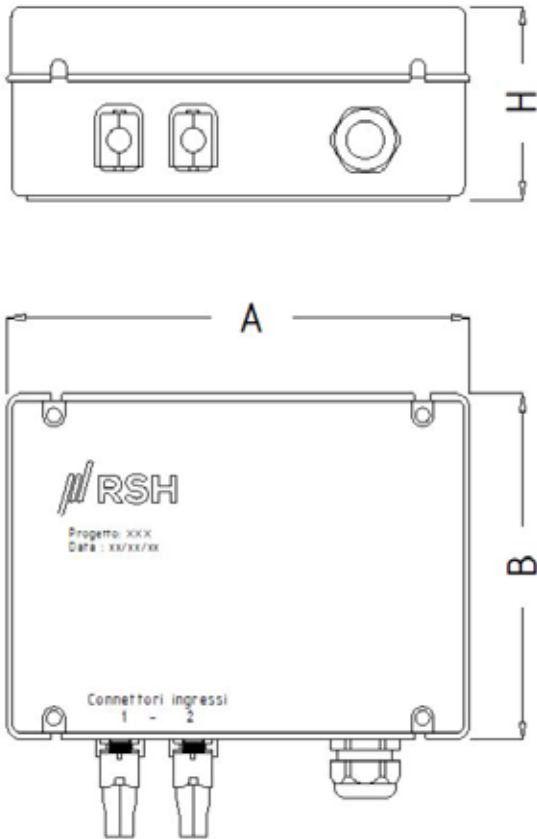

The CLE boards are pre-wired, tested, and ready to be installed on board. They are used to manage the solenoid valves, the pumps, and the various control inputs. They range from the simplest to those equipped with an electronic controller (PLC).

The versions managed by PLC, equipped with the basic software, allow you to assign to each individual function the speed and maximum working pressure, the ability to manage up to two power sources, and the ability to interface with the external touch screen. All information can be displayed in real time on the touch-screen.

On the touch screen, all the operating parameters can be set or modified by assigning to each maneuver its operating mode and the related safety working limits.

Obviously, it is possible to customize the hardware and related software for any specific request or need.

Technical Data

Ref.	Description	A (mm)	B (mm)	H (mm)
CLE-01	7 Way PLC control box	315	230	127
CLE-02	12 Way PLC control box	315	230	127
CLE-TS7	7" color touch screen 800×480 TFT-LCD	200	146	8

CLP motorized pumps

The long experience in the field has led us to select very reliable components with a particular focus on their energy efficiency and their silence.

Our systems can be powered, even at the same time, by diverse sources with different engines ranging from traditional electric motors to brushless electric motors to PTO driven by endothermic engines.

You can therefore combine pumps, even of different nature, by optimizing and managing different pressure / flow parameters for the various components by means of micro programmable controllers.

The standard range offers electric motors from 0.8 to 3 kW with or without electronic flow control.

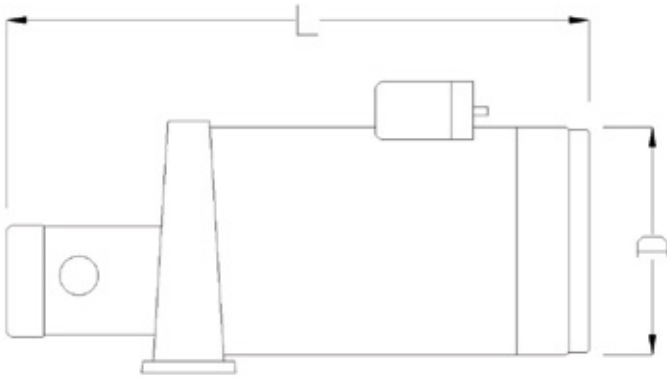

Technical Data

Ref.	Description	L (mm)	D (mm)
CLP-0K8-24	800W 24V Pump	280	80
CLP-2K-24	2 kW 24V Pump	366	114
CLP-3K-24	3 kW 24V Pump	408	160

E440 Quick release valve

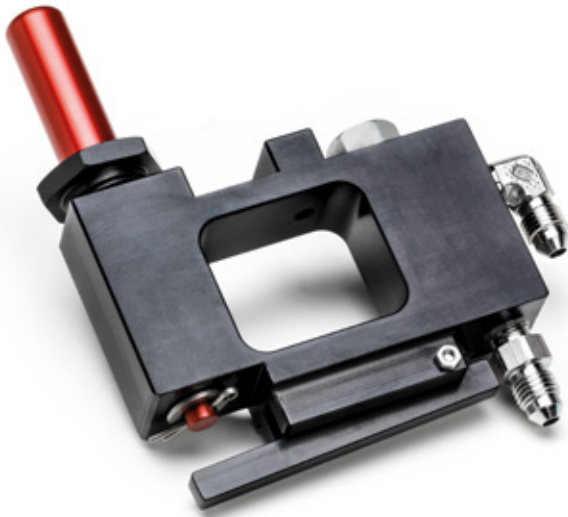

Easy to operate by pressing the button by hand or by feet, is used to quickly release the function on which it is mounted.

It was born as a panic button to be inserted in the vang circuit and it can be used wherever an immediate release is needed.

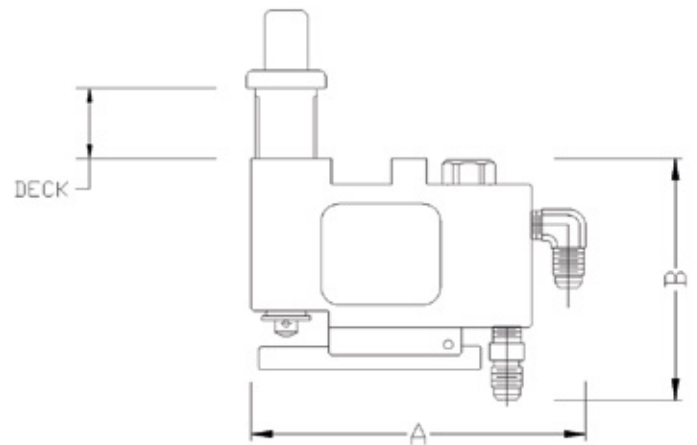

Technical Data

Ref.	Description	Working pressure (psi)	A (mm)	B (mm)	Deck (mm)	Weight (kg)
E440-A-01A	Quick release valve	5000	121	87	3 - 25	0.39

EH120 Fixed clevis



Our clevis are made in black hard-coated aluminum for the minimal wieght.

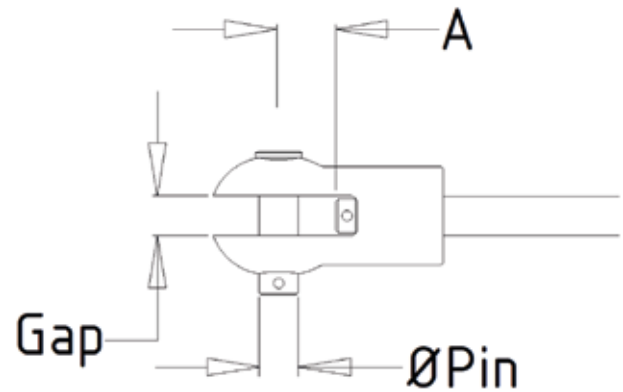

Technical Data

Ref.	Description	Gap / Pin (in)	A (mm)
EH120-10	-10 aluminum fixed clevis	1/2	21
EH120-17	-12 / -17 aluminum fixed clevis	5/8	26
EH120-22	-22 aluminum fixed clevis	3/4	25.5
EH120-30	-30 aluminum fixed clevis	7/8	41.7
EH120-40	-40 aluminum fixed clevis	1	38.7
EH120-60	-60 aluminum fixed clevis	1 1/4	49.7
EH120-90	-90 aluminum fixed clevis	1 3/8	61.7

EJ100 Toggle



The toggle between the hull and the cylinder allows perfect alignment of the load in all working conditions in the various settings.

A simple expedient to minimize the side loads.

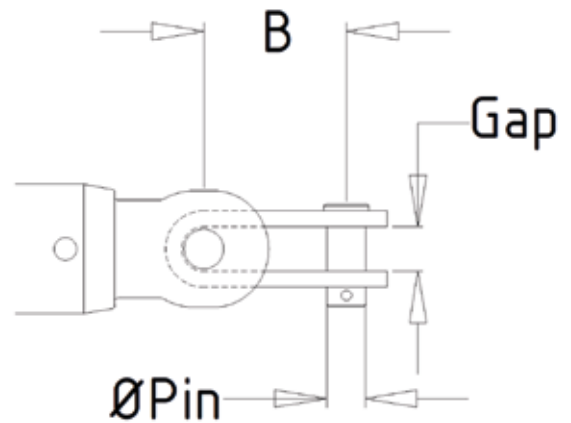

Technical Data

Ref.	Description	Gap / Pin (in)	B (mm)
EJ100-10	-10 Cylinder toggle	1/2	50
EJ100-17	-12/-17 Cylinder toggle	5/8	60
EJ100-22	-22 Cylinder toggle	3/4	70
EJ100-30	-30 Cylinder toggle	7/8	80
EJ100-40	-40 Cylinder toggle	1	90
EJ100-60	-60 Cylinder toggle	1 1/4	115
EJ100-90	-90 Cylinder toggle	1 3/8	115